

AV-508 Investment Casting Stainless Steel (CF8M) Ball Valve, Screwed Ends

Features

Body Material Cum Standard	Cast Stainless Steel (ASTM A351 Gr. CF8M)
Port Opening	Full Bore
Product Description	Two Piece Design, Lever Operated (Blow Out Proof Stem)
Type of Seat	Renewable Seat
Trim	Ball & Stem: Stainless Steel (AISI 316), PTFE Seats
End Details	Screwed Female BSP Parallel Threads (BS-21)
Test Pressure	1000 Psig (Hyd.)



Notes

Suitable for steam service with specialized PTFE.
Can be provided with Glass Filled PTFE, Graphite Blended PTFE & PEEK Seats on request.
Other screwed end specifications can be provided on request.

Suitability

Water, Steam, Gas, Oil, Air

Material Combination

S.No	Description	No.	Material
1	Connector	1	Cast Stainless Steel
2	Seat	2	PTFE
3	Ball	1	Cast Stainless Steel
4, 5	Gasket, Stem Seal	1	PTFE
6	Packing	-	PTFE
7	Gland Nut	1	Stainless Steel
8, 10	Stem, Stem Nut	1	Stainless Steel
9	Spring Washer	1	Stainless Steel
11	Lever	1	Stainless Steel Sheet
12	Body	1	Cast Stainless Steel

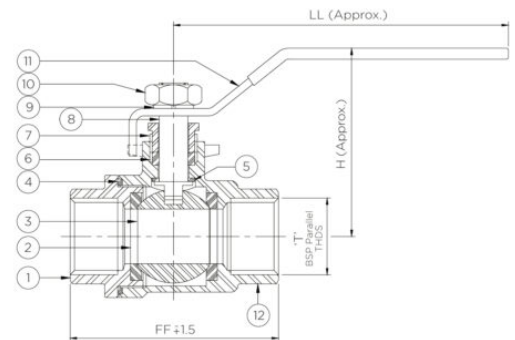

Dimensional Data

Size (mm)	Size (inches)	FF	H	LL	T
8	1/4"	62	50	100	1/4"
10	3/8"	62	50	100	3/8"
15	1/2"	56	52	113	1/2"
20	3/4"	63	57	113	3/4"
25	1"	78	63	116	1"
32	1.1/4"	77	80	145	1.1/4"
40	1.1/2"	98	85	152	1.1/2"
50	2	108	93	152	2