

FV-505 Forged Brass Ball Valve, Screwed Ends, PN-25

Features

Product Standard	BS EN 17292
Pressure / Class Rating	PN-25
Body Material Cum Standard	Forged Brass (IS 6912 Gr. FLB)
Port Opening	Full Bore
Product Description	Two Piece Design, Lever Operated (Blow Out Proof Stem)
Type of Seat	Renewable Seat
Trim	Ball & Stem: Cu-Alloy, PTFE Seats
End Details	Screwed Female BSP Parallel Threads (BS-21)
Test Pressure	Body: 550 Psig (Hyd.), Seat: 400 Psig (Hyd.), Seat: 100 Psig (Air)



Suitability

Water, Gas, Oil, Air

Material Combination

S.No	Description	No.	Material
1	Body Connector	1	Forged Brass
2	Ball	1	Forged Brass
3	Seat	2	PTFE
4	Gasket	1	PTFE
5	Packing Ring	-	PTFE
6	Gland	1	Brass
7	Lever	1	Carbon Steel
8	Locking Nut	1	Brass
9	Stem	1	Brass
10	Body	1	Forged Brass

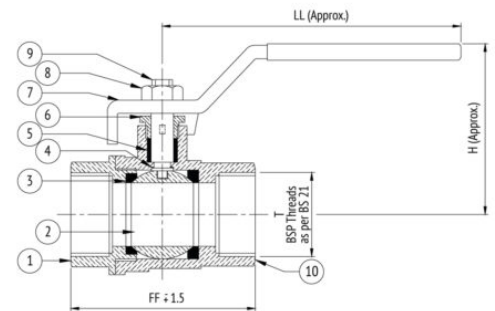

Dimensional Data

Size (mm)	FF	LL	H	T
15	50	96	48	1/2"
20	58	102	52	3/4"
25	63	102	54	1"
32	80	168	79	1.1/4"
40	90	117	82	1.1/2"
50	103	157	83	2"
65	135	217	125	2.1/2"
80	150	225	125	3"
100	180	225	150	4"